



WARN Industrial Hoist

Model

Part Number

Motor Type

DC2000 (LF)

85160

DC Electric
24 Volt
Permanent
Magnet

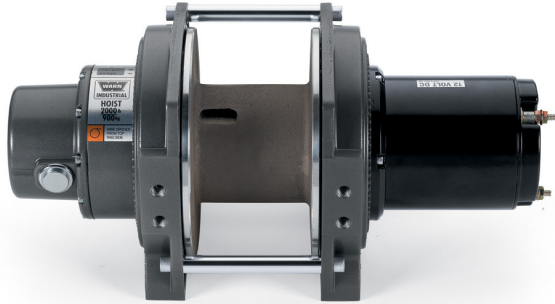

The DC2000 hoist combines a powerful permanent magnet DC motor with robust sealing and our proven 3-stage all metal geartrain. Permanent grease lubrication means years of trouble free service. All WARN hoists incorporate an automatic mechanical brake that holds full rated load. The durable powder coated finish stands up to the elements and looks great. The DC2000 hoist is built on WARN's robust large frame design with a cast aluminum drum to provide plenty of wire rope capacity. Controls and accessories available separately.

Accessories

Description:	Part Number
Control Pack-24V	63752
Contactors Only-24V (Standard bracket)	34968
Contactors Only-24V (w/ bracket for cover)	34974
Contactors Cover (with remote plug)	36648
Contactors Cover (no plug)	35169
Remote Control Only	34462

*12V model shown in photo

Engineering Data

Rated Capacity:	2000 lbf	907 kgf
Drum Barrel Diameter:	4.25 in	108 mm
Drum Flange Diameter:	8.25 in	210 mm
Distance Between Flanges:	3.79 in	96 mm
Recommended Maximum Wire Rope Diameter:	1/4 in	6.4 mm
Recommended Minimum Wire Rope Breaking Strength:	7000 lbf	3175 kgf
Approximate Shipping Weight:	50.0 lb	22.7 kg
Duty Cycle (intermittent per SAE J706 section 6.2):	N/A ft	N/A m
Mounting Bolt Torque:	35 - 40 ft*lbf	47 - 54 N*m
Maximum Layers of Wire Rope:	5	
Gear Reduction:	261	
Brake Type:	Automatic Cone	
Contactors/Remote Type:	Not Included	

Drum Rotation



Viewed from Motor End

Standards Compliance

1. - CE Machinery Directive 98/37/EC and 2006/42/EC
2. - CE Electromagnetic Compatibility 2004/108/EC
3. - ASME B30.5

Performance By Layer

Drum Layer	Line Load *			No Load Line Speed		Drum Capacity	
	lbf	kgf	kN	ft/min	m/min	ft	m
1	2000	907	8.9	14.3	4.4	16	4.9
2	1800	816	8.0	15.9	4.8	34	10.4
3	1636	742	7.3	17.5	5.3	53	16.2
4	1500	680	6.7	19.1	5.8	74	22.6
5	1385	628	6.2	20.6	6.3	97	29.6

* Never exceed the Rated Capacity. Installation of a Rated Capacity Limiter is recommended.

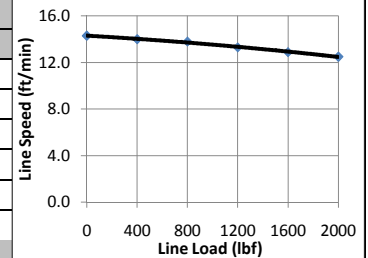

First Layer Performance

Line Load		Current Draw	Line Speed		Duty Cycle
lbf	kgf	Amps	ft/min	m/min	min/10min
0	0	6	14.3	4.4	Continuous
400	181	15	14.0	4.3	Continuous
800	363	23	13.8	4.2	Continuous
1200	544	33	13.3	4.1	6.8
1600	726	43	12.9	3.9	4.6
2000	907	54	12.5	3.8	3.4

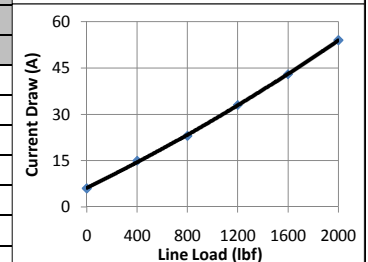

WARN INDUSTRIES, INC
Industrial Products

Customer Service (North America): 1.800.543.9276
Customer Service (International): 1.503.722.3008
FAX: 1.503.722.3000 www.warn.com

12900 S.E. Capps Road,
Clackamas, OR USA 97015



WARN Industrial Hoist

Model	Part Number	Motor Type
DC2000 (LF)	85160	DC Electric 24 Volt Permanent Magnet

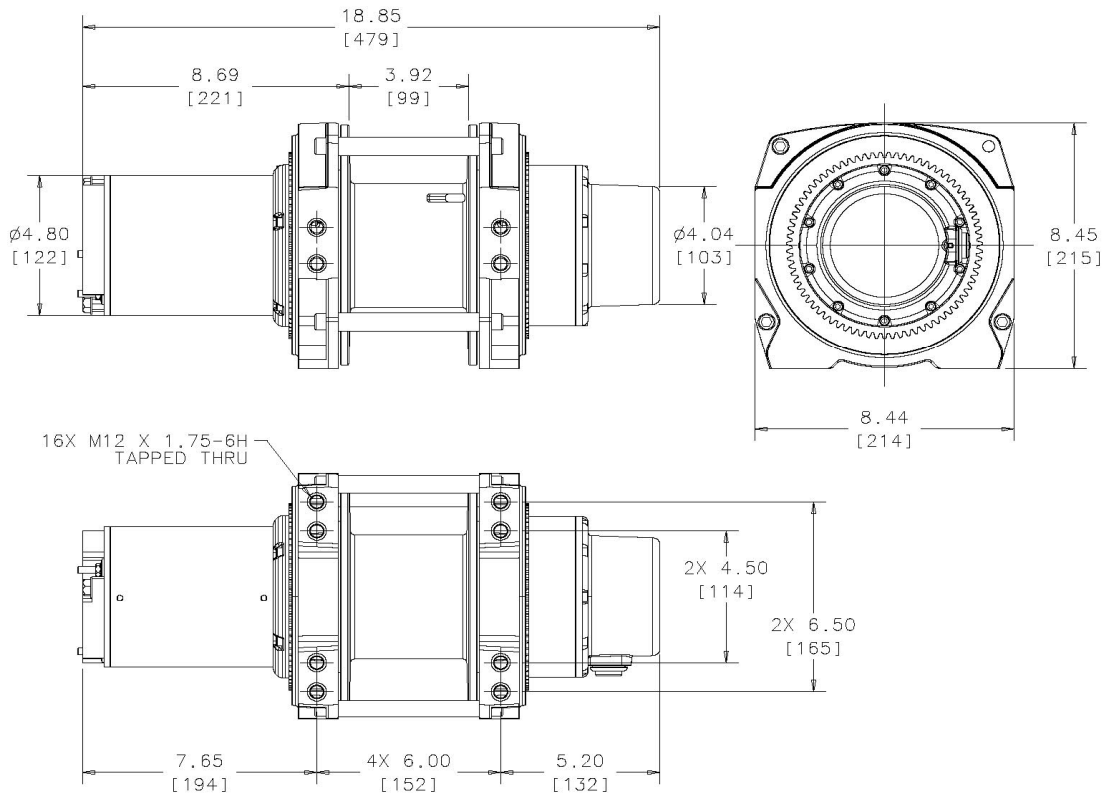

Units are given in inches [millimeters], unless otherwise specified

Recommended Mounting (Always Observe Correct Drum Rotation)			Electrical System Specifications
<p>Pull from bottom of hoist</p> <p>Feet down</p>	<p>Pull from bottom of hoist</p> <p>Feet forward</p>	<p>Pull from top of hoist</p> <p>Feet forward</p>	<p>See Electrical Cable Gauge Size Chart for cable sizing</p> <p>All electrical connections must be clean and tight</p>
<p>Pull from top of hoist</p> <p>Feet down without angle brace</p>	<p>Pull from top of hoist</p> <p>Feet down with angle brace</p>	<p>Pull from top of hoist</p> <p>Angle Braces Only</p>	<p>Electrical System Wiring Schematic</p> <p>Hoist provided without electrical controls. See accessories on front page for control kits.</p> <p>Power IN (Hoisting)- Connect motor terminal #2 to positive. Connect motor terminal #1 to negative (Ground).</p> <p>Power OUT (Lowering)- Connect motor terminal #1 to positive. Connect motor terminal #2 to negative (Ground).</p> <p>Notes:</p>

WARN INDUSTRIES, INC
Industrial Products

Customer Service (North America): 1.800.543.9276
Customer Service (International): 1.503.722.3008
FAX: 1.503.722.3000 www.warn.com

12900 S.E. Capps Road,
Clackamas, OR USA 97015